

# CROQUET.SPORT™

## HOUSE RULES FOR 6 WICKET GAME

A standard court size is 84 x 105 feet and is laid out as shown below. Dimensions may be adjusted to fit the size and shape of the space available. Flags mark the boundary corners of the actual playing rectangle. Pegs are placed at the ends of each of the four yard lines, which create another rectangle 36 inches inside the court. These yard lines are important for starting play and for out-of-bounds ball replacement.

Balls must pass through all wickets in the proper order and direction as indicated. Each wicket so made counts as one point. Each ball can score 13 total points, 12 wicket points and 1 finish stake point. The first team (or player) to completely finish the course and strike the finish stake, called "stake-out", wins. Games with time limits may use points to determine the winner.

In doubles, each player plays one ball and there are generally two players per team. One team plays blue and black, the other team plays red and yellow and so on. If your group is short one person, then a single player can play both balls as if a team.

In singles, each player plays two balls without a partner. One player plays blue and black, the other player plays red and yellow and so on.

In individual cutthroat, each player plays one ball without a partner.

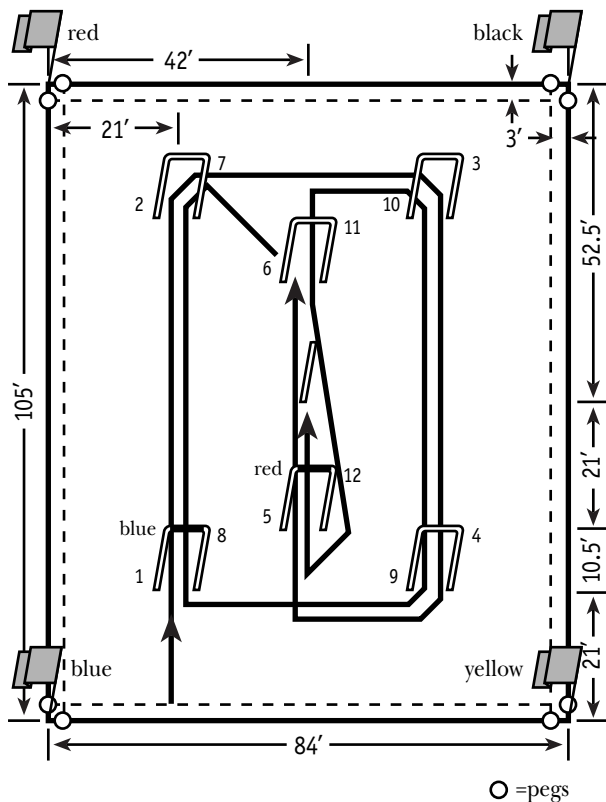

Croquet.Sport™ house rules may be different from official association rules. Rules for the American styled six wicket, nine wicket and golf croquet play are available from the United States Croquet Association. Rules for international play are available from the Croquet Association (United Kingdom) and from other national associations of croquet enthusiasts worldwide.

- 1 Toss for Start.
- 2 Each ball is brought into play by making the first wicket in turn by color (as they are painted on the stake). Start in front of the first (blue top) wicket from the yard line (thirty six inches inside the boundary line). If you fail to make the first wicket during your turn, pick up your ball and start again on your next turn. Play is made only by using the face of your mallet to strike your ball. You may never use your mallet to directly strike a wicket, a stake or another ball. Successful play typically advances your ball (or your partner's ball), hinders your opponent's progress or earns bonus strokes.
- 3 When you make a wicket during a turn, place your clip (corresponding to your ball's color) on the next wicket or stake. Correct clip placement is on the crown of the wicket until wicket number seven, and then correct placement is on the side of the wicket until the finish stake. Correct clip placement is on the black spire for the stake.
- 4 Bonus strokes are awarded by:
  - Making a wicket (earns one bonus stroke) or
  - Striking another ball with your ball, called "roqueting" (earns two bonus strokes) or
  - Deciding that some players receive bonus strokes to be used on any turn as suits the player until used up. These bonus strokes are called 'bisques' and are awarded according to ability as handicap to make the game more competitive. Agreement before the start establishes who gets bisques (and how many).
- 5 After roqueting another ball, you have three options:
  - Take two bonus strokes starting from where your ball has come to rest.
  - With ball in hand, place your ball one mallet's head length away (in any direction) from where the other (roqueted) ball has come to rest and then take two bonus strokes.
  - With ball in hand, place your ball in contact with the other (roqueted) ball where it has come to rest and then use one of your bonus strokes to strike your ball so as to send both balls in the desired direction. This first bonus stroke is called taking a croquet stroke. It's also permitted to rest your foot on your own ball so as to render it immobile during this shot. Your next bonus stroke starts from where your ball now has come to rest. This second bonus stroke is called taking a continuation stroke.
- 6 Other balls may be roqueted only once for bonus strokes during each turn, unless you make the next wicket in the proper order and direction, after which all other balls may again be roqueted for bonus strokes. Remember, a ball that has not made the first wicket is not yet in play and can neither roquet another ball nor be roqueted.
- 7 Bonus strokes may not be accumulated. Only the last earned bonus strokes may be played. There are two exceptions to this rule:
  - If you make a wicket and then roquet another ball with a single stroke.
  - If bisque strokes are awarded they may be played in addition to earned bonus strokes.
- 8 If another player (partner or opponent) puts your ball through a wicket in the proper order and direction, your side gets the point but no bonus stroke.
- 9 If you roquet more than one ball during a single stroke, you get bonus strokes only from the first ball roqueted, with the other balls remaining where they came to rest.
- 10 Rover balls are balls that have completed the entire course except for staking-out. Typically, rover balls avoid a premature stake-out so that they can continue to advance a partner's progress or hinder an opponent's. Rover balls earn bonus strokes only by roqueting other balls, not by making wickets. Other balls may be roqueted only once during each turn by a rover ball. A rover ball is finished and removed from the game when staked-out. A rover ball may be staked-out by any player with any legal stroke at any point during the game.
- 11 A ball sent out-of-bounds is brought in bounds without penalty. Replace the ball opposite the point of exit on the yard line (thirty six inches inside the boundary line) and play it as if that is where it came to rest.